

***Your proven answer
to soundproof ventilation
in noise affected buildings.***

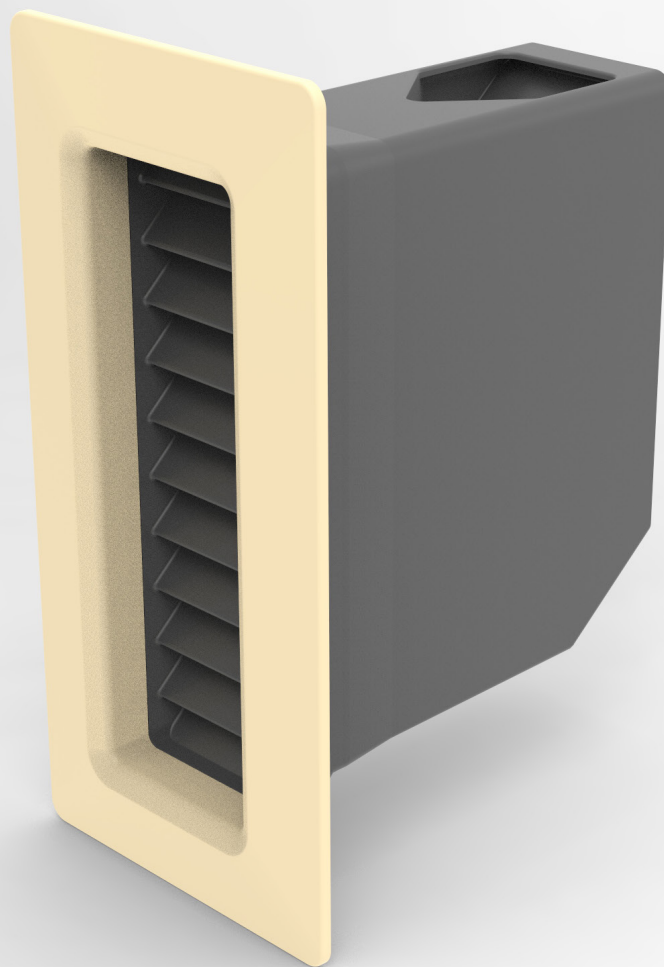

Vertical Exterior Storm Louvre

Product Code: 23-01-03



Best new product
DesignBuild Australasia



Top 10 Eco Product in the USA
Sustainable Building Magazines



Silver Medal
International Salon des Inventions.
Geneve, Switzerland

Information

The Silenceair vertical exterior storm louvre is designed to be used when the Silenceair acoustic ventilator is installed in a horizontal orientation, for example, over a door head.

The louvre unit consists of 2 separate storm louvre systems and an integrated insect screen.

It designed so that any water that may collect in the unit will simply drain out.

The body of the unit is black, whilst the snap fit cover plate can be painted to match the colour scheme of the building.

The basic unit is designed for installation in a CFC walling system. For thicker materials, such as Hebel panel. A version of the product with a longer body is available.

Product Code

- 23-01-01: Natural Black
- 23-01-03: White
- 23-01-50CC: Custom Colour

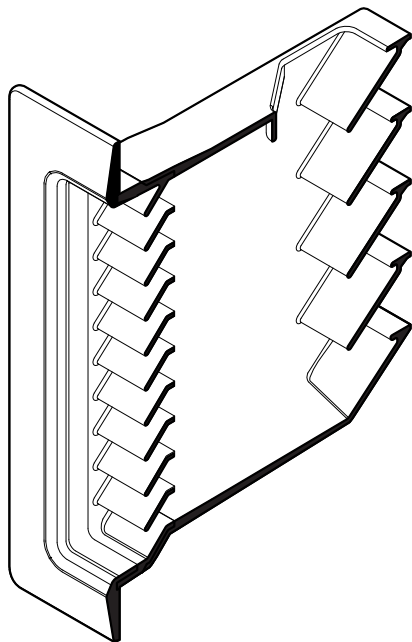

Showing the two layers of louvre.

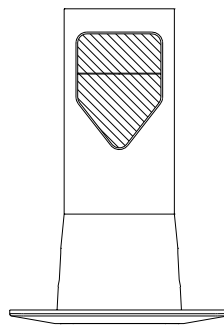

TOP VIEW

96mm

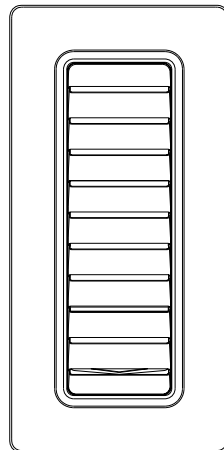

FRONT VIEW

132mm

196mm

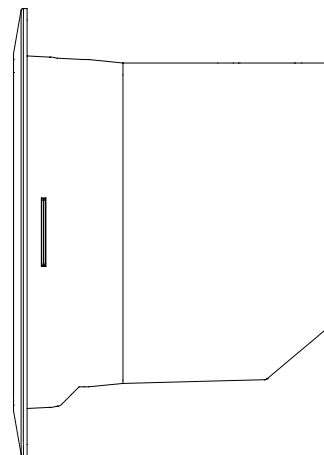

SIDE VIEW

Open Vent Area 5,200mm²
Weight 0.204 kg
Material Recyclable ABS

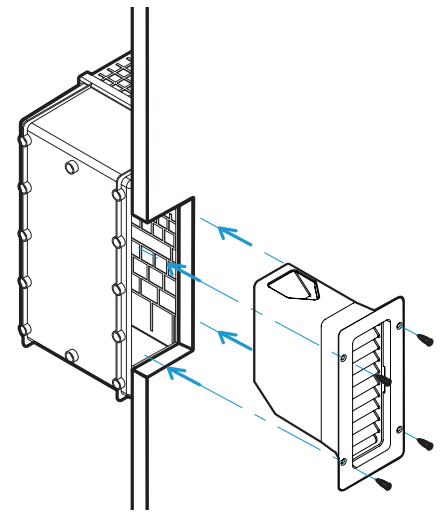

Screw fix the body into the wall.

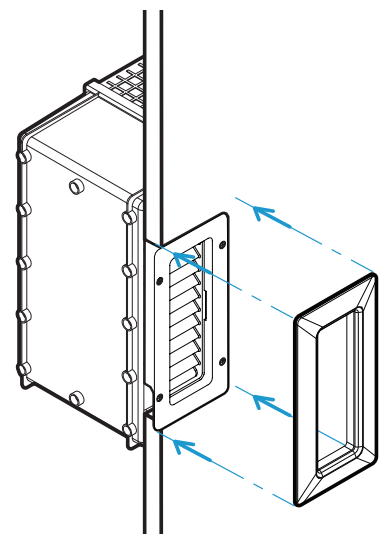

Snap fit the cover plate into position.

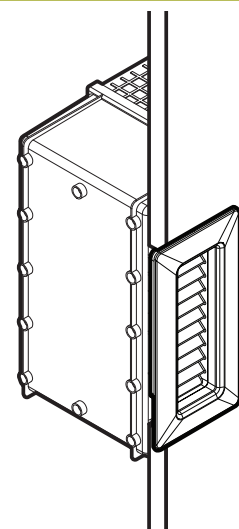

The Silenceair acoustic ventilator is completely hidden in the wall, only the colour coordinated weather louvre is visible.

For more information please contact

www.silenceair.com enquiries@silenceair.com +61 2 9555 7215

Patents and Patents Pending Silenceair is a registered trademark of Silenceair International Pty Limited