

*Your proven answer
to soundproof ventilation
in noise affected buildings.*

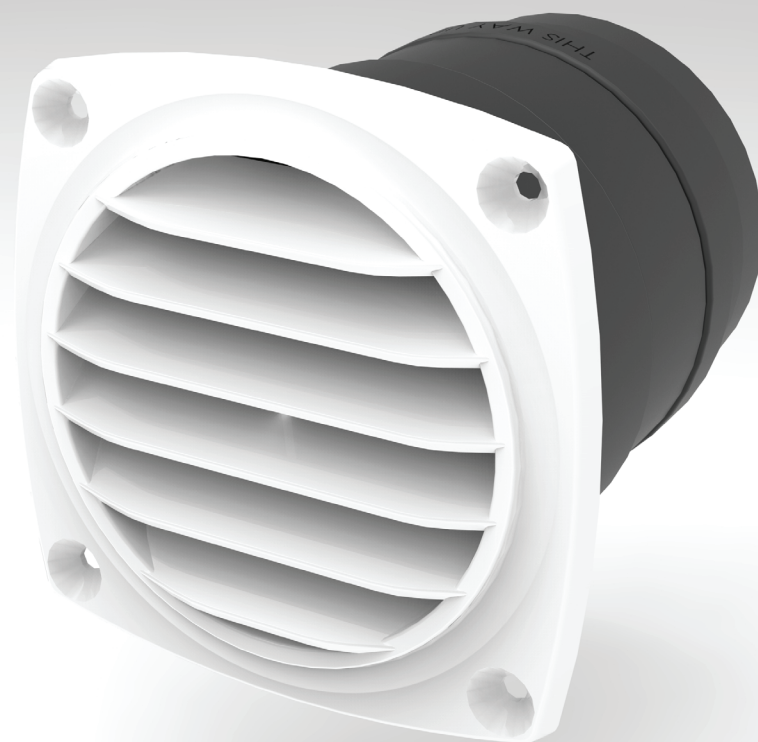

75 Diameter Weather louvre

Product Code: 24-01-01



Best new product
DesignBuild Australasia



Top 10 Eco Product in the USA
Sustainable Building Magazines



Silver Medal
International Salon des Inventions.
Geneve, Switzerland

Information

The Silenceair 75 diameter weather louvre with paintable cover is designed to be installed in external wall systems where a 100mm diameter penetration is preferred.

This weather louvre offers a complete weather seal between the Silenceair acoustic unit and the weather louvre. The joints can be sealed with standard plumbers adhesive. The system is suitable for exposed positions. Any wind driven rain that may enter the system will simply drain out through the louvre.

The weather louvre comprises an exterior louvre cover, an integral insect screen, an extension tube, and an internal louvre spray guard. The exterior cover can be painted to match the building colour scheme.

The length of the extension tube can be cut to suit the thickness of the wall.

Note. When ordering this weather louvre, ensure you order the Silenceair 64mm acoustic ventilator with round adaptor.

Product Code

24-01-03: Natural Black
 24-01-01: White
 24-01-50CC: Custom Colour

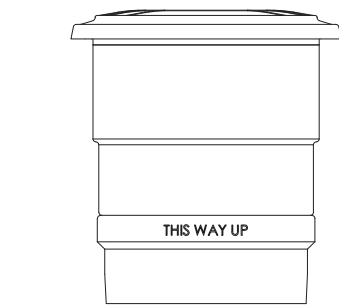

74mm

TOP VIEW

92mm

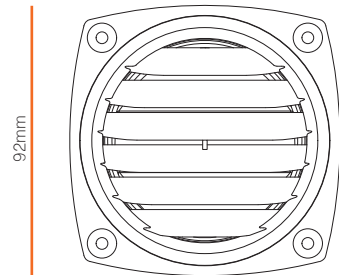

92mm

FRONT VIEW

98mm

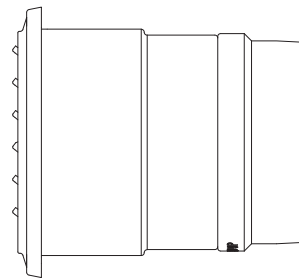

SIDE VIEW

Open Vent Area 5,200mm²

Weight 0.116 kg

Material Recyclable ABS

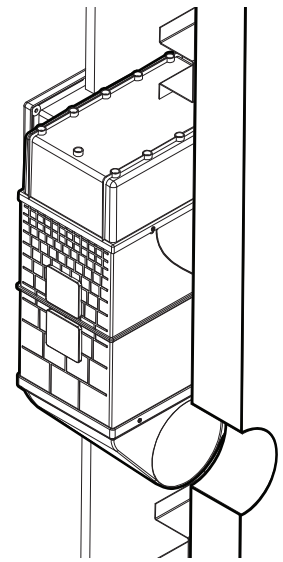

Fit the Silenceair unit into place and mark the location of the exterior penetration on the wall.

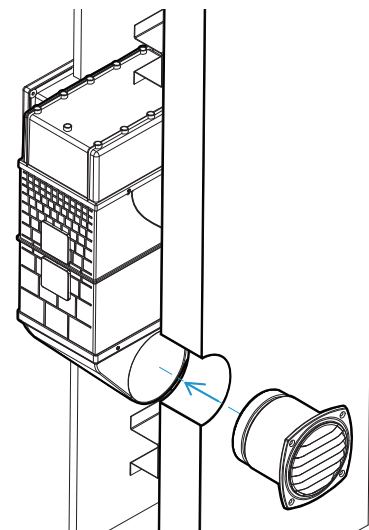

Drill out the hole and insert the assembled weather louvre unit. Ensure extension tube has been cut to the correct length to allow a tight fit.

Section View

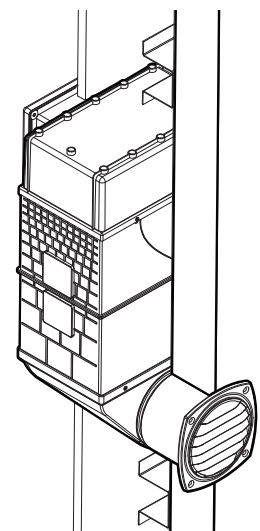
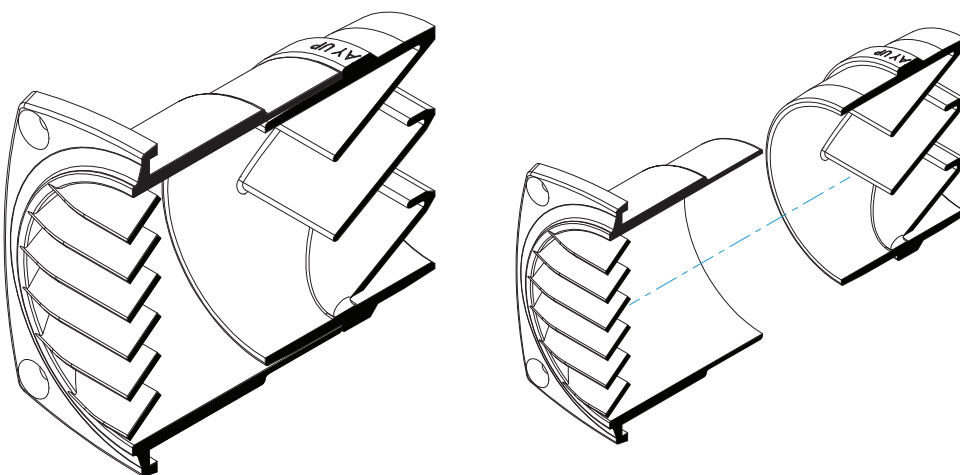

Fix into place.

For more information please contact

www.silenceair.com enquiries@silenceair.com +61 2 9555 7215

Patents and Patents Pending Silenceair is a registered trademark of Silenceair International Pty Limited